

MOBILE CRUCIBLE FURNACES

Typ. MVTP - EM

DESCRIPTION:

Electrically heated bale out furnace suitable for melting and holding of non-ferrous-metals.

ADVANTAGES OF CRUCIBLE FURNACES:

- quiet operation
- minimal heat loss
- no need for suction
- high accuracy of temperature regulation

LONCE:

V peči se vgrajujejo grafitni ali SiC lonci.

FURNACE SIZES:

250 - 1100 kg of Aluminium
(other sizes can be made on request)



TEMPERATURE CONTROL:

Through a thermocouple in the wall of the crucible and in the heating chamber, each with electronic temperature regulators. Regulation is possible from the heating chamber only. Automatic switching-on by timer with weekend switching-off device. The energy consumption is checked through an amperemeter.

TECHNICAL DATA:

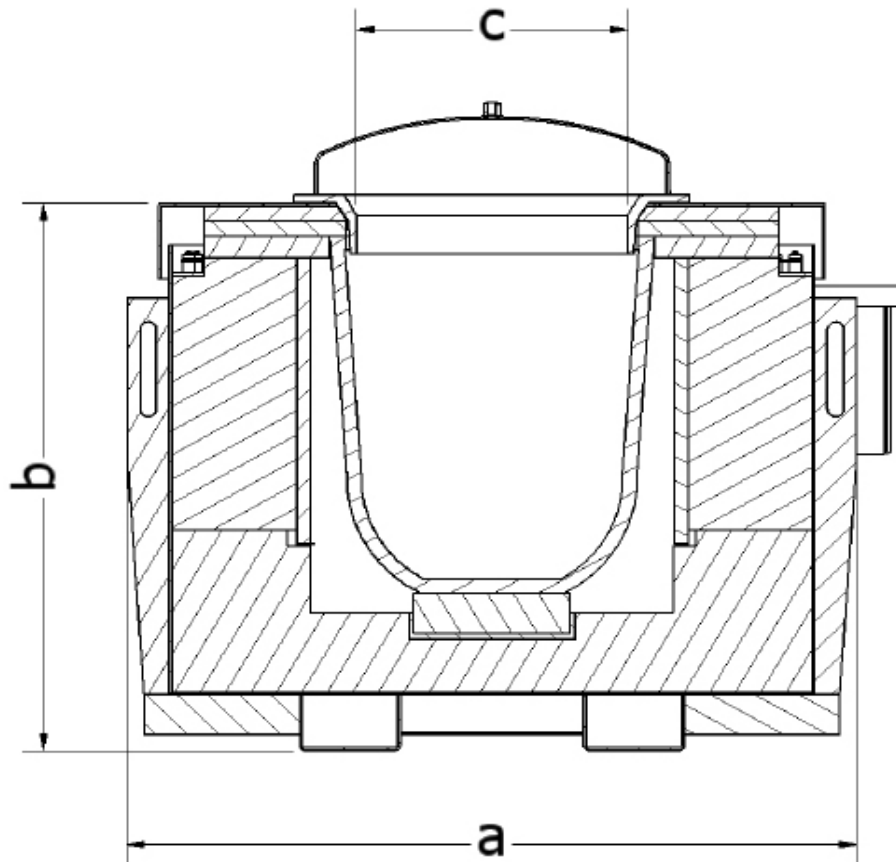

Size	Crucible size	Quantity of Al. kg	Power supply		Dimensions (mm)			
			normal	increased	a	b	c	d
MVTP -EM 250	BU 250	250	45 kW	55 kW	1500	1200	500	-
MVTP -EM 300	BU 300	300	45 kW	55 kW	1500	1200	500	-
MVTP -EM 350	BU 350	350	55 kW	65 kW	1600	1200	600	-
MVTP -EM 500	BU 500	500	68 kW	80 kW	1750	1400	650	-
MVTP -EM 600	BU 600	600	68 kW	80 kW	1750	1400	650	-
MVTP -EM 750	BU 750	750	90 kW	110 kW	1750	1400	750	-
MVTP -EM 800	BU 800	800	90 kW	110 kW	1850	1400	750	-
MVTP -EM 900	BU 900	900	110 kW	135 kW	1900	1550	750	-
MVTP -EM 1100	BU 1110	1100	110 kW	135 kW	1900	1450	850	-

INTERMETAL

Proizvodnja strojev in livarske opreme d.o.o.
Krupa 10, 8333 Semič, Slovenija

Tel: 386 (0) 7 35 68 230

Fax: 386 (0) 7 35 68 231

E-mail: intermetal@siol.net

Internet: www.intermetal.si