

CRUCIBLE FURNACES

Typ. SVTP - ES

DESCRIPTION:

Electrically heated bale out furnace suitable for melting and holding of non-ferrous-metals.

ADVANTAGES OF CRUCIBLE FURNACES:

- quiet operation
- minimal heat loss
- no need for suction
- high accuracy of temperature regulation

CRUCIBLE:

Depending on the material graphite or SIC crucible can be installed.

FURNACE SIZES:

250 - 1100 kg of Aluminium
(other sizes can be made on request)



TEMPERATURE CONTROL:

Through a thermocouple in the wall of the crucible and in the heating chamber, each with electronic temperature regulators. Regulation is possible from the heating chamber only. Automatic switching-on by timer with weekend switching-off device. The energy consumption is checked through an amperemeter.

TECHNICAL DATA:

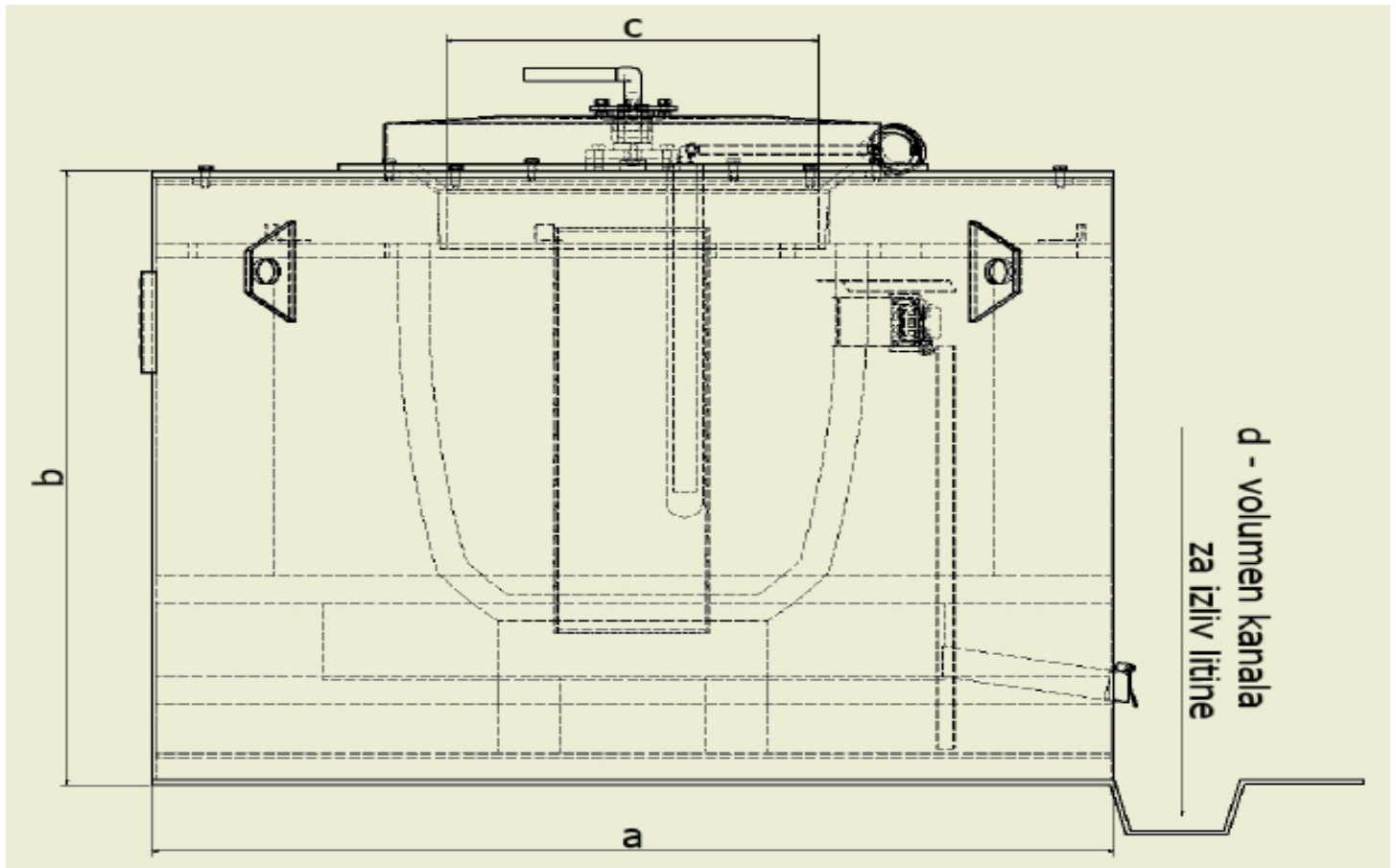

Size	Crucible size	Quantity of Al. kg	Power supply		Dimensions (mm)			
			normal	increased	a	b	c	d (l)
SVTP -ES 250	BU 250	250	45 kW	55 kW	1350	1100	500	120
SVTP -ES 300	BU 300	300	45 kW	55 kW	1350	1100	500	120
SVTP -ES 350	BU 350	350	55 kW	65 kW	1550	1550	600	150
SVTP -ES 500	BU 500	500	68 kW	80 kW	1550	1250	650	200
SVTP -ES 600	BU 600	600	68 kW	80 kW	1650	1300	650	250
SVTP -ES 750	BU 750	750	90 kW	110 kW	1650	1250	750	300
SVTP -ES 800	BU 800	800	90 kW	110 kW	1650	1350	750	320
SVTP -ES 900	BU 900	900	110 kW	135 kW	1650	1450	750	360
SVTP -ES 1100	BU 1110	1100	110 kW	135 kW	1750	1550	850	400

INTERMETAL

Proizvodnja strojev in livarske opreme d.o.o.
Krupa 10, 8333 Semič, Slovenija

Tel: 386 (0) 7 35 68 230

Fax: 386 (0) 7 35 68 231

E-mail: intermetal@siol.net

Internet: www.intermetal.si